

# ECOTROC® CTAP 6 - 65

## Operating manual

### Oil vapor adsorber

Rev 02\_0224

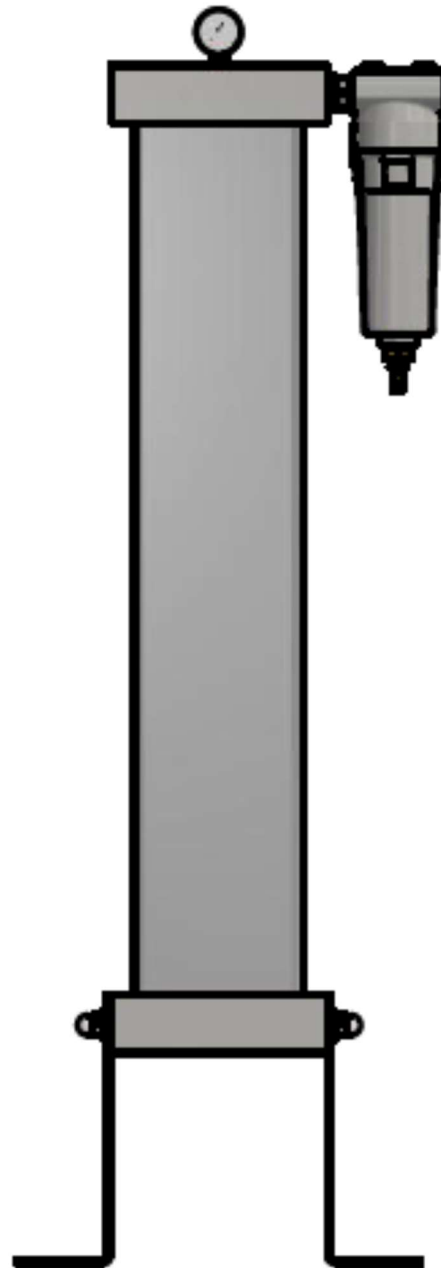

## Contents

<b>1</b>	<b>General information</b>	<b>3</b>
1.1	System data	3
1.2	Contact data	3
1.3	Accompanying documents	3
1.4	Warranty notes	4
1.5	Operating manual	4
1.6	Signs and symbols used	5
<b>2</b>	<b>Intended purpose / use</b>	<b>6</b>
2.1	Intended use	6
2.2	Performance data	7
<b>3</b>	<b>Safety notes</b>	<b>8</b>
3.1	Signs and symbols	8
3.2	Danger zones	9
<b>4</b>	<b>Technical product data</b>	<b>10</b>
4.1	Equipment overview, front view	10
4.2	Function description	10
<b>5</b>	<b>Monitoring the operation</b>	<b>11</b>
<b>6</b>	<b>Transport, storage and setup</b>	<b>11</b>
6.1	Transport	11
6.2	Storage	11
6.3	Setup	12
<b>7</b>	<b>Installation</b>	<b>12</b>
7.1	Recommendations for installation	12
7.2	Demands on the installation	13
7.3	Elimination of hazards	13
<b>8</b>	<b>Commissioning</b>	<b>13</b>
8.1	Commissioning pre-requirement	13
8.2	Pressurization	14
8.3	Mains operation	14
8.4	Disconnecting from the mains	15
<b>9</b>	<b>Maintenance</b>	<b>16</b>
9.1	Regular maintenance work	16
9.2	Daily checks	16
9.3	Checking the residual oil content	17
9.4	Overview of maintenance parts	20
9.5	Replacing the filter elements	21
9.6	Replacing the active carbon	22
<b>10</b>	<b>Faults</b>	<b>23</b>
<b>11</b>	<b>Manufacturer's declaration</b>	<b>24</b>
<b>12</b>	<b>EC Declaration of conformity</b>	<b>25</b>

# 1 General information

Please complete the following information according to the type plate, vessel plate and contract documents. This enables the manufacturer to clearly identify the dryer and makes it easier to give advice if there are queries. It also simplifies the provision of spare parts and support. This may correspond to separate pieces of equipment for the individual devices.

## 1.1 System data

Model: \_\_\_\_\_

Order No.: \_\_\_\_\_

Serial number: \_\_\_\_\_

Year of manufacture: \_\_\_\_\_

Date of commissioning: \_\_\_\_\_

## 1.2 Contact data

Company: \_\_\_\_\_

Address: \_\_\_\_\_

Phone: \_\_\_\_\_

E-Mail: \_\_\_\_\_

## 1.3 Accompanying documents

Applicable documents which are not included with this documentation:

- Installation drawing
- Documentation for additional equipment parts)

## **1.4 Warranty notes**

For the conditions necessary for compliance with the warranty, please refer to our "General Terms of Sale and Delivery"

The warranty shall be void if:

- The adsorption dryer is used for anything other than its intended use.
- The instructions in this operating manual are not observed.
- External influences (e.g. aggressive substances) cause damage to the oil vapor adsorber.
- Maintenance intervals are not adhered to.
- Damage is caused due to incorrect or defective maintenance.
- The adsorption dryer is operated although defects are evident.
- The oil vapor adsorber is operated although defects are evident.
- An unfavorable or incorrect installation is selected.

## **1.5 Operating manual**

This operating manual will help clarify any outstanding questions concerning the setup, installation, operation, maintenance, repair and disposal of the dryer. It contains useful tips and advice.

It is not only written for the operator who is responsible for monitoring the daily operation of the device, but also for the service personnel who performs the installation and service. Maintenance and repair work may only be carried out by qualified personnel!









This operating manual must be read before any installation and maintenance work is started. All safety instructions must be observed!

The operating manual must be kept in the vicinity of the adsorption dryer.

As already mentioned in the warranty notes, the manufacturer accepts no liability for damages resulting from disregard of the operating manual.

## 1.6 Signs and symbols used

The following symbols are listed in this manual and/or are affixed to the construction:

Symbol	Bedeutung
	Tip This symbol indicates tips for the efficient use of the adsorption dryer!
	Note This symbol indicates instructions for the safe handling of the adsorption dryer.
	Caution / Warning This symbol indicates general hazards or dangerous situations.
	Danger! Compressed air This symbol warns of dangers due to compressed air.
	Danger! High voltage This symbol warns of dangers due to electric voltage.
	Slip hazard This symbol warns of the risk of slipping.
	Personal protective equipment – Ear protectors Wear ear protectors
	Personal protective equipment – Respiratory protection Wear respiratory protection
	Personal protective equipment – Goggles Wear goggles

## 2 Intended purpose / use

The oil vapor adsorber is designed to be used to reduce the oil vapor fractions in the compressed air and reduce odorous and aromatic substances in industrial compressed air systems. It requires the supply of compressed air from a supply source.

The main task is to reduce vaporous oil fractions in the compressed air. Upstream filters and dryers ensure that only particles and drop shapes are separated. By applying the pretreatment process of the active carbon which is specifically designed for this purpose, the long-chain hydrocarbons from the compressed air are stored in the open pores of the active carbon and the oil fraction of the compressed air is reduced to a minimum. Compressor oils are perfectly absorbed by the active carbon. Should you want to absorb other substances, please contact the manufacturer.

### 2.1 Intended use

The oil vapor adsorber is exclusively designed for cleaning compressed air! If the oil vapor adsorber is to be used with other gases, this must be agreed with the manufacturer. Other safety guidelines may apply here!

The oil vapor adsorber must be set up at a site indoors:



- which is suitable for the weight,
- weatherproof (exposure to sun should be avoided),
- dry,
- frost-free,
- vibration-free,
- not in potentially explosive atmospheres,
- which can be accessed for maintenance and servicing.



The oil vapor adsorber must only be operated within the allowable operating conditions. These are defined on the type plate and vessel plate. Any other use is considered improper and the manufacturer accepts no liability.

The oil vapor adsorber must not be converted in any way and its components must not be modified. The use of components other than the original ones from the manufacturer is not permitted, unless this has been agreed with the manufacturer.

The values shown on the vessel plate are the maximum permissible values as per the pressure equipment directive. These values are not meant for the operating conditions. The maximum operating conditions can be found on the type plate of the oil vapor adsorber.

For the nominal performance data of the adsorption dryer, please refer to the Section "Performance data".

Exceeding or even significantly undercutting the design data can lead to bad residual oil contents!

The compressed air supplied to the oil vapor adsorber must be of the following quality:

- Free from aggressive and corrosive substances,
- Free from particles and solids,
- Dry (technically dry),
- Must be within the temperature conditions for the design.



In principle, the adsorption dryer can also be operated without any pre-treatment, but this may be detrimental to the service life of the adsorbent. Droplets of oil and particles are stored in the open pores and reduce the adsorption capacity of the adsorbent.



Where temperatures are above 131 °F, previously collected oil can be released again!

## 2.2 Performance data

The performance data of the individual types of devices is shown in the table below. The data are based on the operating conditions of the compressed air temperature + 95 °F and 102 psi operating pressure, and a moisture content < 30%.

Type	Nominal volumetric flow rate cfm	Connection Inlet (Oil vapor adsorber)	Connection Outlet (Afterfilter)
CTAP 6	6	1/4" NPT	3/8" NPT
CTAP 12	12	1/4" NPT	3/8" NPT
CTAP 20	20	1/2" NPT	3/8" NPT
CTAP 30	30	1/2" NPT	3/8" NPT
CTAP 35	35	1/2" NPT	1/2" NPT
CTAP 40	40	1/2" NPT	1/2" NPT
CTAP 55	55	1/2" NPT	1/2" NPT
CTAP 65	65	1/2" NPT	1/2" NPT

Based on 14.5 psi (a) and 154 °F



According to the definition in the pressure equipment directive, pressure vessels are not subject to repeated tests. If necessary, regional or national specifications can be applied in addition or as supplementary. The adsorption dryers are inspection-free, according to the definition of the pressure equipment directive.

### 3 Safety notes

The ATC oil vapor adsorbers have been built according to state-of-the-art technology and the latest safety regulations. However, there is still a risk of danger during operation, maintenance, installation and servicing, and during transport and setup. In particular, the disregard of safety regulations when handling compressed air may result in serious injury or death. Expertly trained personnel and those trained in safety should therefore only use the system.



- Observe the safety notes in this manual and on the adsorption dryer.
- Observe all safety notes, even those in the individual chapters.
- Observe all legal guidelines and safety regulations (the latter may vary from region to region!)
- Observe all local site regulations which are stipulated for the field of application.

#### 3.1 Signs and symbols

The following signs are affixed to the adsorption dryer:

Type plate (on the right side of the vessel)

It shows details of the type, year of manufacture, serial number of the device, performance data, weight and filters installed.

Only once on the adsorption dryer:

Type plate:



The type plate on the device shows important information. Please make sure that they are always legible and that they can be accessed.



## 3.2 Danger zones

Risk from pressure-bearing parts



Risk of slipping due to spilt desiccant on the floor

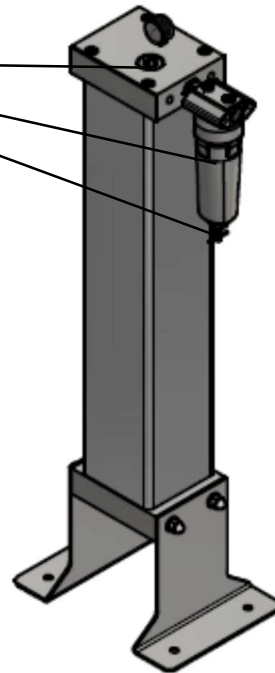

- Never operate the adsorption dryer outside of the load limits shown on the vessel plate.
- Never carry out work if the adsorption dryer is under pressure.
- Do not modify the structure of the adsorption dryer or change its function.
- Only use the adsorption dryer for its intended purpose.
- Do not climb onto the device.
- Do not carry out welding work on pressure-bearing parts.
- Wear respiratory protection and eye protection when changing the active carbon.
- Risk of slipping due to spilt active carbon.
- Always check that the indicator pipe is secure before you open the needle valve and remember to wear eye protection.
- Never operate the device if there is apparent damage.
- Avoid sparks and naked flames in the vicinity of the active carbon as it is combustible.
- Never lift the oil vapor adsorber by the equipment parts, only use the lifting lugs.

### Active carbon

The active carbon used does not fall into the hazardous substances group and is therefore not subject to labelling requirements. Nevertheless, please observe all common safety measures regarding using chemicals. Please also note that the material accumulates contaminants, in particular oil. This can cause additional dangers.

Should you require further information, contact the manufacturer to obtain a copy of the safety datasheet.

## 4 Technical product data

### 4.1 Equipment overview, front view

- 1 After-filter
- 2 Manometer
- 3 Filling nozzle
- 4 Draining nozzle
- 5 Inlet
- 6 Outlet
- 7 Manual drain cock

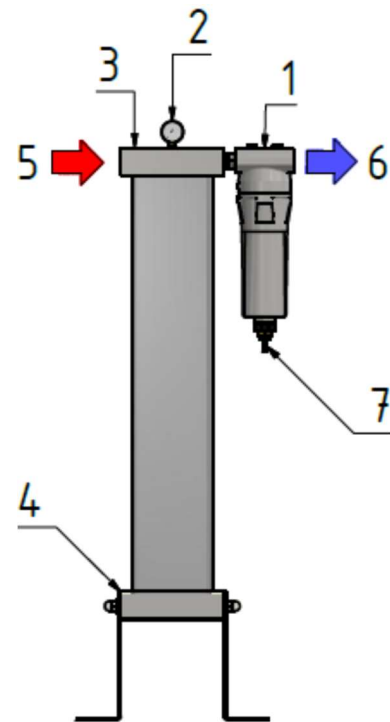

### 4.2 Function description



From the filled adsorbent material, (active carbon in this case), oil vapors and odorous and aromatic substances are stored in the open pores of the active carbon, thus reducing its content in the compressed air.

Through the joining pipe and possible pre-treatment, the compressed air is fed via the inlet into the diffuser (flow distributor and sieve). The compressed air is hereby distributed over the whole vessel cross-section for optimum efficiency. Based on the laws of physics and a calculated and required contact time, the abovementioned moisture content is stored in the open pores of the desiccant. The cleaned air then exits the vessel again through a sieve on the outlet.

As the temperatures rise, the performance of the active carbon is reduced since the hydrocarbon chains (oils) become shorter and shorter and cannot be absorbed as effectively.

The contaminations collected in the active carbon gradually saturate the material. It cannot be regenerated in the process and must be replaced. With the appropriate compressed air quality at the inlet, it is possible for the service life to exceed 10,000 hours.

## 5 Monitoring the operation

The following components are provided for regular monitoring:

The pressure gauge shows the operating pressure.

As option it is possible to mount an oil check indicator.

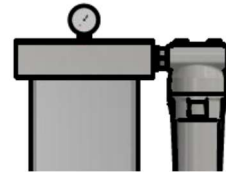

Based on the discoloration, the indicator provides information about the saturation of the active carbon.

## 6 Transport, storage and setup

### 6.1 Transport

**i** Although great care is taken, please check immediately whether the adsorption dryer has been damaged in any way. Any kind of transportation damage must be pointed out immediately to the deliverer and manufacturer.

- Suitable hoisting equipment must be provided for the transportation, loading and unloading process.
- The device must only be lifted at the designated points: crane hook or transport pallet.
- Take the weight of the adsorber into account and provide suitable assistive equipment.
- Do not remove the packaging material until the device is moved to its place of installation.
- Only appropriately qualified personnel may carry out the abovementioned tasks.
- Observe all regulations on accident prevention.

### 6.2 Storage

**i** If the adsorber needs to be stored before being commissioned, ensure that the storage site fulfils the following requirements:

- Indoors only
- Dry
- Frost-free
- Protected against weather impact.

**i** If the device is stored after having been commissioned, please proceed as follows:

- Depressurize the adsorber.
- Disconnect the adsorption dryer from the compressed air system.
- Close the compressed air inlet and outlet.

## 6.3 Setup



Please refer to the setup conditions described in Section 2.1. The basic data required for the setup can be found in the Performance data in Section 2.2.

When setting up, make sure

- that the ground is level and capable of bearing the weight.
- Make sure there is enough space around the adsorber to carry out the servicing and maintenance work. We recommend at least 0.8 m.
- Make sure that the adsorber can be reached and accessed by the lifting gear.
- The adsorber must not be accessible to non-experts, or warning signs should be affixed for inexperienced persons.
- The adsorber cannot be rammed by haulage vehicles.
- The signage is always clearly visible.

There are mounting holes in the base section of the adsorption dryer. These should be used to anchor the device into the ground, if the ground allows it.

## 7 Installation

### 7.1 Recommendations for installation



Proper installation is the basic prerequisite for the safe and problem-free operation of the CTAP series.

We recommend the installation of shut-off devices both upstream and downstream of the adsorber. The adsorber can thereby be disconnected from the compressed air system during maintenance.

If operation cannot be interrupted during maintenance, then a by-pass line must be provided. It should at least include an active carbon filter to prevent a contamination of oil downstream of the adsorber.



We recommend installation after a corresponding pre-treatment. The oil vapor adsorber is usually installed behind an air cauldron and dryer (compressed air refrigeration dryer or adsorption dryer).

A filter with a separation degree of 0.01  $\mu$  must be installed immediately in front of the oil vapor adsorber to collect any possible additional liquid drops and solids which would otherwise cause the active carbon to become saturated more quickly.

Installing the device behind an air cauldron also has the advantage in that pulsating compressed air is buffered and the temperature at the inlet of the adsorber is lower.

Choose a place of installation with the lowest possible compressed air temperature and with the highest level of dry air. This then increases the service life of the active carbon and the adsorber works most efficiently.

## 7.2 Demands on the installation

Prior to installation, check the following points:



- The compressed air system and the adsorption dryer must be free from pressure.
- For compressed air systems which need to remain under pressure, shut-off devices must be protected against unintentional opening.
- The operating pressure in the system cannot be higher than the maximum permissible operating overpressure of the adsorber.
- There must be no pressure surges in the system in the desiccant (e.g. from valves which open abruptly).
- The pipelines are designed for the operating pressure, nominal width and volume.
- No possible vibration transmission or vibration.
- No residue left in the pipeline from mechanical processing.

## 7.3 Elimination of hazards

Please be aware of the risks associated with the installation of the device:



- Do not work on parts which are under pressure.
- The pipelines must hold in place with brackets; the adsorption dryer is not designed to act as a support for the pipes.
- The adsorber must only be used in the predetermined operating conditions (see vessel plate), it is the operator's duty to observe these values.

## 8 Commissioning



All work on CTAP adsorbers and on the feeder and drainage systems must only be carried out by expertly trained persons and by those with experience in the field of compressed air!

### 8.1 Commissioning pre-requirement

The following points must be checked immediately prior to commissioning:



- The maximum operating values must not be exceeded.
- Upstream and downstream shut-off devices are closed.
- All connections and screw connections are secure. Check this and tighten if necessary using a suitable tool.
- Visually check again for any signs of damage. Do not use the adsorption dryer if it is damaged in any way.

## 8.2 Pressurization



Only once you have successfully completed all the checks listed in Section 8.1 can you perform the following steps in the specified order.

Wear ear protection for this, as the flow noise can get very loud.



- Make sure that the compressed air system is under pressure upstream of the adsorber.
- Slowly open the cut-off valve upstream of the adsorber until you hear the flow noise.
- Keep an eye on the pressure gauge on the vessel. Pressurization must rise slowly.
- At 58 psi close the inlet shut-off device again. Check all connections for leaks. If leaks are found, the adsorber must be rendered pressureless again and the leaks must be repaired.
- If no further flow noises can be heard and if the pressure gauge does not indicate any further increase in pressure, you can open the cut-off valve completely.

## 8.3 Mains operation

Pressurization has been successful. Check whether the compressed air system downstream of the adsorption dryer can be opened safely. Then proceed as follows:



- Slowly open the cut-off valves at the outlet of the adsorption dryer until you hear the flow noise.
- Keep an eye on the pressure gauge. Should the pressure suddenly drop, check whether any tapping points are still open.
- If the pressure remains stable and you no longer hear any flow noise, the cut-off valve downstream of the adsorption dryer can be opened completely.
- Start the controller. Once switched on, it can take 1 minute until the first valve is opened.
- Keep an eye on the pressure gauges. The operating pressure must be virtually "0" on the expanding side. The expansion noise is loud, only quiet flow noises should be perceived after this.
- Once regeneration has been completed, pressurization starts. During this time, the previously opened valve must be closed and pressurization must start again.
- Once the pressurization time has passed, the pressure on both vessels must be virtually the same.
- Now also consider the expansion (regeneration) on the other side. If this also works as described above, the adsorption dryer is ready for operation.

## 8.4 Disconnecting from the mains



Should you have to disconnect the adsorption dryer from the mains, e.g. for a maintenance operation, make sure that this work is only carried out when the device is free from pressure.



Wear your personal protective equipment. Proceed as follows:



- Close the cut-off valves at the inlet and outlet of the adsorber.
- Open the manual drain on the after-filter housing.

Man. drain cock

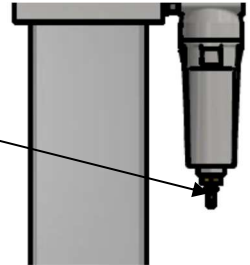

- Keep an eye on the pressure gauge and wait until it displays "0" psi before starting work.
- Then close the manual cock again.

The oil vapor adsorber is now disconnected from the mains.

## 9 Maintenance



Maintenance work may only be carried out by suitably qualified personnel! Make sure that the device is free from pressure before starting work and observe the applicable accident prevention regulations for the place of installation!

### 9.1 Regular maintenance work

The following table gives an overview of the intervals and scope of the maintenance work:

Maintenance of	Activity	Every day	Every month	Every year
Adsorber and filters	Visual check, functional check	X		
Oil check indicator (OPTIONAL)	Residual oil content measurement		X	
Oil check indicator (OPTIONAL)	Replace pipe if discolored	if necessary		
After-filter element	Replace the filter element			X
Active carbon	Replace			rec. after 4.000 Bh / or 1 year
Seals	Replace			X
Sieves	Clean, replace if necessary			X

### 9.2 Daily checks

The following points should be checked every day:

- The difference in the operating pressure upstream and downstream of the adsorption dryer is not more than 7 psi.
- Open the manual drain cock slightly on the after-filter. It must not drip.
- Check if you can hear any unusual or loud noises.
- Check for leaks.
- If prefilters are installed, check that the condensate drains work properly.



### 9.3 *Checking the residual oil content*

The residual oil content should be measured on a regular basis. Proceed as follows:

Check that the indicator pipe is secure.

- Record the date and time when measurements start.
- Record the operating pressure (it should be constant during the measurement).
- Record the scale value where the obvious red discoloration can already be seen. (ignore any slight pink-colored discoloration)
- Open the needle valve completely.
- Allow the measurement to run its course until there is a discoloration of a scale unit of at least 0.2. Use the following tables with the corresponding measurement pressure to determine the ppm content for the corresponding measurement time.
- If your measurement value is within the table values (e.g. 0.5 scale units are discolored), you can interpolate this value.
- Multiply this value by 1.2 to obtain the residual oil content in  $\text{mg}/\text{m}^3$ .
- Also assess the discoloration rate by recording the values at regular intervals. This provides you with information about the service life of the active carbon.
- You can use the test pipe until it is completely discolored, then replace it.
- An example at the end of the table clarifies the selection.
- Close the needle valve again. If more measurements need to be taken, continue to measure from the obvious red discolored area.
- Replace the completely discolored test pipe when the device is depressurized.



Table for measurement pressure **greater than 102 psi (g)**, residual oil content in **ppm**

<b>Scale</b>	<b>0.2</b>	<b>0.4</b>	<b>0.6</b>	<b>0.8</b>	<b>1.0</b>	<b>1.2</b>	<b>1.4</b>	<b>1.6</b>
<b>Duration in h</b>								
<b>4</b>	0.548	1.096	1.644	2.192	2.740	3.288	3.836	4.384
<b>4.5</b>	0.496	0.992	1.488	1.984	2.480	2.976	3.472	3.968
<b>5</b>	0.452	0.904	1.356	1.808	2.260	2.712	3.164	3.616
<b>5.6</b>	0.404	0.808	1.212	1.616	2.020	2.424	2.828	3.232
<b>6.3</b>	0.358	0.716	1.074	1.432	1.790	2.148	2.506	2.864
<b>7.2</b>	0.312	0.624	0.936	1.248	1.560	1.872	2.184	2.496
<b>8.4</b>	0.270	0.540	0.810	1.080	1.350	1.620	1.890	2.160
<b>10</b>	0.224	0.448	0.672	0.896	1.120	1.344	1.568	1.792
<b>12.5</b>	0.180	0.360	0.540	0.720	0.900	1.080	1.260	1.440
<b>16.6</b>	0.136	0.272	0.408	0.544	0.680	0.816	0.952	1.088
<b>25</b>	0.090	0.180	0.270	0.360	0.450	0.540	0.630	0.720
<b>33</b>	0.068	0.136	0.204	0.272	0.340	0.408	0.476	0.544
<b>50</b>	0.045	0.090	0.135	0.180	0.225	0.270	0.315	0.360
<b>56</b>	0.040	0.079	0.119	0.158	0.198	0.238	0.277	0.317
<b>63</b>	0.036	0.072	0.109	0.145	0.181	0.217	0.253	0.290
<b>72</b>	0.032	0.064	0.096	0.128	0.160	0.192	0.224	0.256
<b>84</b>	0.027	0.055	0.082	0.110	0.137	0.164	0.192	0.219
<b>100</b>	0.023	0.045	0.068	0.090	0.113	0.136	0.158	0.181
<b>125</b>	0.018	0.036	0.055	0.073	0.091	0.109	0.127	0.146
<b>166</b>	0.014	0.028	0.041	0.055	0.069	0.083	0.097	0.110
<b>250</b>	0.009	0.018	0.026	0.035	0.044	0.053	0.062	0.070
<b>500</b>	0.004	0.009	0.013	0.018	0.022	0.026	0.031	0.035
<b>1000</b>	0.002	0.004	0.006	0.008	0.010	0.012	0.014	0.016

Table for measurement pressure **87 psi (g)**, residual oil content in **ppm**

<b>Scale</b>	<b>0.2</b>	<b>0.4</b>	<b>0.6</b>	<b>0.8</b>	<b>1.0</b>	<b>1.2</b>	<b>1.4</b>	<b>1.6</b>
<b>Duration in h</b>								
<b>4</b>	0.640	1.280	1.920	2.560	3.200	3.840	4.480	5.120
<b>4.5</b>	0.580	1.160	1.740	2.320	2.900	3.480	4.060	4.640
<b>5</b>	0.524	10.48	1.572	2.096	2.620	3.144	3.668	4.192
<b>5.6</b>	0.454	0.908	1.362	1.816	2.270	2.724	3.178	3.632
<b>6.3</b>	0.416	0.832	1.248	1.664	2.080	2.496	2.912	3.328
<b>7.2</b>	0.364	0.728	1.092	1.456	1.820	2.184	2.548	2.912
<b>8.4</b>	0.312	0.624	0.936	1.248	1.560	1.872	2.184	2.496
<b>10</b>	0.266	0.532	0.798	1.064	1.330	1.596	1.862	2.128
<b>12.5</b>	0.210	0.420	0.630	0.840	1.050	1.260	1.470	1.680
<b>16.6</b>	0.160	0.320	0.480	0.640	0.800	0.960	1.120	1.280
<b>25</b>	0.105	0.210	0.315	0.420	0.525	0.630	0.735	0.840
<b>33</b>	0.078	0.156	0.234	0.312	0.390	0.468	0.546	0.624
<b>50</b>	0.053	0.106	0.158	0.211	0.264	0.317	0.370	0.422
<b>56</b>	0.047	0.093	0.140	0.186	0.233	0.280	0.326	0.373

<b>63</b>	0.042	0.083	0.125	0.166	0.208	0.250	0.291	0.333
<b>72</b>	0.037	0.074	0.110	0.147	0.184	0.221	0.258	0.294
<b>84</b>	0.032	0.064	0.096	0.128	0.160	0.192	0.224	0.256
<b>100</b>	0.027	0.054	0.080	0.107	0.134	0.161	0.188	0.214
<b>125</b>	0.020	0.041	0.061	0.082	0.102	0.122	0.143	0.163
<b>166</b>	0.016	0.032	0.048	0.064	0.080	0.096	0.112	0.128
<b>250</b>	0.011	0.021	0.032	0.042	0.053	0.064	0.074	0.085
<b>500</b>	0.005	0.010	0.016	0.021	0.026	0.031	0.036	0.042
<b>1000</b>	0.003	0.005	0.008	0.010	0.013	0.016	0.018	0.021

Table for measurement pressure **73 psi (g)**, residual oil content in **ppm**

<b>Scale</b>	<b>0.2</b>	<b>0.4</b>	<b>0.6</b>	<b>0.8</b>	<b>1.0</b>	<b>1.2</b>	<b>1.4</b>	<b>1.6</b>
<b>Duration in h</b>								
<b>4</b>	0.700	1.400	2.100	2.800	3.500	4.200	4.900	5.600
<b>4.5</b>	0.700	1.400	2.100	2.800	3.500	4.200	4.900	5.600
<b>5</b>	0.636	1.272	1.908	2.544	3.180	3.816	4.452	5.088
<b>5.6</b>	0.568	1.136	1.704	2.272	2.840	3.408	3.976	4.544
<b>6.3</b>	0.500	1.000	1.500	2.000	2.500	3.000	3.500	4.000
<b>7.2</b>	0.438	0.876	1.314	1.752	2.190	2.628	3.066	3.504
<b>8.4</b>	0.380	0.760	1.140	1.520	1.900	2.280	2.660	3.040
<b>10</b>	0.316	0.632	0.948	1.264	1.580	1.896	2.212	2.528
<b>12.5</b>	0.254	0.508	0.762	1.016	1.270	1.524	1.778	2.032
<b>16.6</b>	0.190	0.380	0.570	0.760	0.950	1.140	1.330	1.520
<b>25</b>	0.126	0.252	0.378	0.504	0.630	0.756	0.882	1.008
<b>33</b>	0.096	0.192	0.288	0.384	0.480	0.576	0.672	0.768
<b>50</b>	0.062	0.124	0.186	0.248	0.310	0.372	0.434	0.496
<b>56</b>	0.057	0.114	0.172	0.229	0.286	0.343	0.400	0.458
<b>63</b>	0.050	0.101	0.151	0.202	0.252	0.302	0.353	0.403
<b>72</b>	0.044	0.088	0.132	0.176	0.220	0.264	0.308	0.352
<b>84</b>	0.038	0.076	0.114	0.152	0.190	0.228	0.266	0.304
<b>100</b>	0.032	0.064	0.096	0.128	0.160	0.192	0.224	0.256
<b>125</b>	0.026	0.051	0.077	0.102	0.128	0.154	0.179	0.205
<b>166</b>	0.018	0.037	0.055	0.074	0.092	0.110	0.129	0.147
<b>250</b>	0.013	0.027	0.040	0.054	0.067	0.080	0.094	0.107
<b>500</b>	0.006	0.012	0.018	0.024	0.030	0.036	0.042	0.048
<b>1000</b>	0.003	0.006	0.009	0.012	0.015	0.018	0.021	0.024

Example of determining the ppm rate:

The measurement is taken at an operating pressure of 87 psi over a period of 50 hours. 0.5 scale units of discoloration have been added.

Using Table 87 psi, select 50 hours. To interpolate to 0.5 scale units, calculate:

$0.106 + 0.158 = 0.264 \text{ ppm} / 2 = 0.132 \text{ ppm}$  based on the measurement time of 10 hours

Converted into  $\text{mg}/\text{m}^3$ , this means:

$0.132 \times 1.2$  (factor for compressor oils) = 0.158 residual oil content in  $\text{mg}/\text{m}^3$

## 9.4 Overview of maintenance parts

Type	Component	Designation	Interval	Measure
CTAP 6	APE-CTAP6-30	After-filter element	Every year	Replace
	A-4000-121	Oil check pipe	Every year / when required	Replace
	F-CTAP6	Filling active carbon	rec. after 4.000 Bh / or 1 year	Replace
CTAP 12	APE-CTAP6-30	After-filter element	Every year	Replace
	A-4000-121	Oil check pipe	Every year / when required	Replace
	F-CTAP12	Filling active carbon	rec. after 4.000 Bh / or 1 year	Replace
CTAP 20	APE-CTAP6-30	After-filter element	Every year	Replace
	A-4000-121	Oil check pipe	Every year / when required	Replace
	F-CTAP20	Filling active carbon	rec. after 4.000 Bh / or 1 year	Replace
CTAP 30	APE-CTAP6-30	After-filter element	Every year	Replace
	A-4000-121	Oil check pipe	Every year / when required	Replace
	F-CTAP30	Filling active carbon	rec. after 4.000 Bh / or 1 year	Replace
CTAP 35	APE-CTAP35-55	After-filter element	Every year	Replace
	A-4000-121	Oil check pipe	Every year / when required	Replace
	F-CTAP35	Filling active carbon	rec. after 4.000 Bh / or 1 year	Replace
CTAP 40	APE-CTAP35-55	After-filter element	Every year	Replace
	A-4000-121	Oil check pipe	Every year / when required	Replace
	F-CTAP40	Filling active carbon	rec. after 4.000 Bh / or 1 year	Replace
CTAP 55	APE-CTAP35-55	After-filter element	Every year	Replace
	A-4000-121	Oil check pipe	Every year / when required	Replace
	F-CTAP55	Filling active carbon	rec. after 4.000 Bh / or 1 year	Replace
CTAP 65	APE-CTAP65	After-filter element	Every year	Replace
	A-4000-121	Oil check pipe	Every year / when required	Replace
	F-CTAP65	Filling active carbon	rec. after 4.000 Bh / or 1 year	Replace

## **9.5 Replacing the filter elements**

The job of the after-filter is to stop any abrasion dust that has built up from the active carbon. Proceed as follows to replace this filter element:

- Close the cut-off valves upstream and downstream of the adsorber.
- Open the manual drain cock on the filter and wait until the pressure gauge on the adsorber shows "0" psi.
- Turn the bottom part of the filter in a clockwise direction to open it. Unscrew it completely and carefully put it down.
- Now you can remove the filter element out of the filter.
- Use a damp cloth to clean inside the filter housing.
- Check whether the O-ring in the filter head is OK. Replace if necessary.
- Please fit the new filter element into the three pockets, on the inside of the filter bowl.
- Screw the bottom part of the filter back in again and close the manual drain cock.
- Slowly open the shut-off device at the outlet and check for leaks.
- Once the pressure is back to normal again, slowly open the shut-off device at the outlet.

## 9.6 Replacing the active carbon



When replacing the active carbon, make sure to wear your personal protective equipment, namely the respiratory protection and goggles.



Risk of slipping if material is spilt!

The service life of the active carbon does not need to be determined with accuracy as there are many factors which can reduce or increase the service life. In favorable conditions, the service life can exceed 10,000 hours. Proceed as follows to replace the active carbon:



- Depressurize the adsorber.
- First, open the sealing plug on the top.
- Place a collecting vessel underneath the bottom sealing plug and remove it.
- Collect the active carbon as it runs out.
- Empty the vessel completely.
- Blow through the sieves inside the vessel.
- Close up the bottom sealing plug again and pour the active carbon material through the top opening.
- Fill in the activated carbon material to the lower edge of the upper diffuser. At higher filling may lead to increased dust content in the afterfilter.
- Screw the top sealing plug back in again.

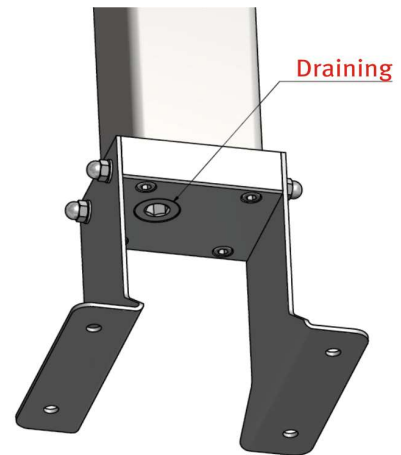

We recommend that you only change the filter element after the active carbon has been changed. To do so, allow the adsorber to run for half an hour. The dust particles that accumulate are hereby captured in the after-filter element which is to be replaced. Only then replace the filter element.

It can happen that the compressed air which has already been dried by an adsorption dryer, becomes moist again (rising pressure dewpoint). This is due to the moisture stored in the active carbon which is rinsed again after a few days.



Contaminated active carbon material must be disposed of in accordance with the local regulations! As a rule, the disposal code is:

"Used active carbon" with the disposal code number: 06 13 02

If other toxic or hazardous substances have been stored, then this must be determined by the operator and the active carbon must be disposed of taking the type of contamination into consideration!

## 10 Faults

The following faults may occur:

<b>Fault</b>	<b>Cause</b>	<b>Measure</b>
Oil in the compressed air downstream of the adsorber	Volumetric flow via the adsorber exceeds the intended parameters Inlet temperature is too high Operating pressure is too low (reduction of flow rate) Active carbon is saturated Large quantity of oil has broken through the compressor Pipes / consumer downstream of the adsorber were already contaminated with oil By-pass line is open / not sealed Highly pulsating compressed air	Adapt to operating conditions Upstream cooling Replace active carbon Close by-pass Replace or clean pipes / consumer
Significant differential pressure	Filter elements saturated Cut-off valves not fully open Dust fraction too high due to pressure shocks Clogged pipes High levels of turbulence at inlet	Replace elements Check shut-off devices Stop pressure shocks Remove active carbon from the vessel until the top dust sieve is exposed

# 11 Manufacturer's declaration

## Manufacturer's declaration

We, the manufacturer,

KSI Filtertechnik GmbH  
Siemensring 54-56  
D-47877 Willich

hereby declare that for the assemblies listed below:

Adsorption dryer ECOTROC CTAP Type 6 to 12

the harmonised standards:  
DIN EN ISO 12100-1-2 have been adhered to.

The pressure vessels belonging to these products have been tested in accordance with European Directive 2014/68/EU Annex I on pressure equipment in construction, and Directive 2014/29/EU on simple pressure vessels and design according to the technical rules of the AD2000 data sheets manufactured.

A CE marking with regard to the Pressure Equipment Directive, is not relevant for the devices as they fall under Art. 4 Para. 3 of the directive:

Dryer size	Amount of chambers	Max. operating pressure psi (g)	Volume per chamber	Category (PED)	Module
CTAP 6	1	232	1.85 L	Art. 4 Abs. 3	Art. 4,3
CTAP 12	1	232	2.31 L	Art. 4 Abs. 3	Art. 4,3

Willich, 01.06.2019

Signed:



Holger Krebs,  
Managing Director



## 12 EC Declaration of conformity

### EU Declaration of conformity

We, the manufacturer,

KSI Filtertechnik GmbH  
Siemensring 54-56  
D-47877 Willich

hereby declare that for the assemblies listed below:

Adsorption dryer ECOTROC CTAP Type 20 to 65

the harmonised standards:  
DIN EN ISO 12100-1-2

DIN EN ISO 12100-1-2; DIN EN ISO 14121-1; DIN EN 55011; DIN EN 61000-6-2,  
61000-3-2, 61000-3-3 have been adhered to.

The conformity assessment procedure was carried out in accordance with Module A.

The pressure vessels belonging to these assemblies were manufactured in accordance with the European Directive 2014/68/EU Annex I on pressure equipment in design and construction in accordance with the technical rules of the AD2000 data sheets.

Any changes to the product not agreed with the manufacturer invalidate this declaration.

Dryer size	Amount of chambers	Max. operating pressure psi (g)	Volume per chamber	Category (PED)	Module
CTAP 20	1	232	5.21 L	I	A
CTAP 30	1	232	6.2 L	I	A
CTAP 35	1	232	7.2 L	I	A
CTAP 40	1	232	9.55 L	I	A
CTAP 55	1	232	11.74 L	I	A
CTAP 65	1	196	14.56 L	I	A

Willich, 01.06.2019

Signed:



Holger Krebs,  
Managing Director