

KONDRAIN®

Condensate Drains



Rev 01_1123

Fully automatic condensate drainage from compressed air and gas systems without loss of compressed air



Premium cost effectiveness

Compressed air generation is as necessary as it is cost intensive. **KONDRAIN®** in a level-controlled, electronic version offers the most effective solution in order to make the most cost effective use possible:

- The intelligent level regulation ensures no unnecessary air loss and therefore no energy loss.
- Condensate is only removed safely and securely when it has accumulated in the drain.

This makes the best cost effectiveness for the compressed air system possible at the best price/performance ratio. As a result KSI **KONDRAIN®** condensate drains contribute globally to significantly increasing the efficiency of production sites.

Premium reliability

The **KONDRAIN®** series offers the highest level regulated, fully automated reliability. This helps to avoid condensate breaches and contamination in the compressed air system. At the same time **KONDRAIN®** reliably protects compressed air-

The KONDRAIN® Plus-Effects +++

- + no unnecessary compressed air loss saves operating costs
- + proven technology, suitable for every condensate type
- + maximizes operational reliability by protecting installations, processes and products
- + assures demand-appropriate compressed air quality
- + robust quality, long service life
- + intelligent control, fully automatic monitoring
- + immune to dirt because of integrated sieve filter
- + very service-friendly
- + excellent price/performance ratio

driven installations, control systems, production processes and, ultimately, product quality. The KSI series features an extreme performance spectrum and is therefore capable of reliably discharging condensate types ranging in consistency from 100% oil to 100% water. This provides the highest degree of safety for your compressed air system.

KONDRAIN® N is a high-performance condensate drain that measures the condensate level internally and discharges it using level control, resulting completely without compressed air loss, at maximum condensate volume. The level regulation is reliably assured via the industrial reed contact and float technology that has proven itself millions of times all over the world. This means that a contact float unit that is process-conforming specifically for condensate technology triggers the opening of the release valve when the maximum level is reached for the exact duration until the drain minimum level is reached, allowing the valve to close again.

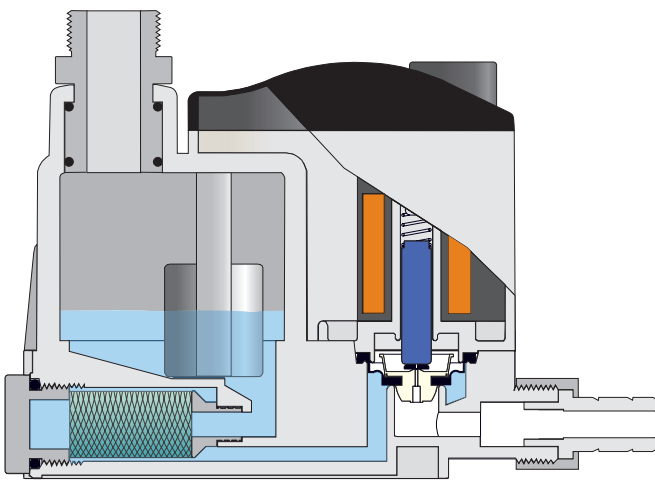

Performance features:

- flexible connection, a 90° rotatable connection facilitates flexible installation
- highly durable Viton membrane
 - ▶ more reliability and long service life
- maximum protection for membrane and function through integrated filter
- functional test is possible at any time via a test button, which can also be used for manual emptying
- self monitoring using intelligent control
- operational protection through auto reset function
- status message in the case of alarm (except model N350)
- zero-voltage contact (except model N350)
- voltage display (except model N350)
- consistent performance level for condensate ranging from 100% oil to 100% water
- just one service kit for the entire series
- ecologically & economically reasonable



KONDRAIN® KMT

Time-controlled condensate drain with free with freely selectable interval time



Features:

- simplest operation
- most compact dimension
- interval time can be optimized at any time
- opening interval can be seen at a glance
- manual emptying possible at any time via test switch
- highest functional safety
- available as **KONDRAIN® KMT-HP** for pressures of 725, 3626, 5076 and 7252 Psi



Specification Modell	N350	N265	N530	N1060	N5580	N10600
Capacity: compressor	350 cfm	265 cfm	530 cfm	1060 cfm	5580 cfm	10600 cfm
Capacity: dryer	710 cfm	530 cfm	1060 cfm	2120 cfm	11160 cfm	21190 cfm
Capacity: filter	3530 cfm	2650 cfm	5300 cfm	10600 cfm	55800 cfm	105950 cfm
Potential-free alarm output	no	yes	yes	yes	yes	yes
Operating pressure	3 to 232 Psi					
Operating Temperature	34 to 140°F					
Available types of voltage	24 V ac (24 V dc on request) 115 V 50/60 Hz					
Safety class	IP 65					

Options



heaters



only one single spare part kit for the complete series

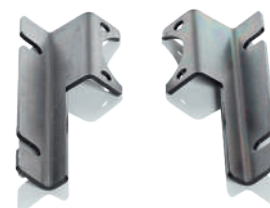

floor mounting kit

KONDRAIN® N-HP

Level- and Time-controlled Condensate Drains · High Pressure



Series N-HP
level-controlled – Hochdruck

KONDRAIN® KN100-HP50 (up to 725 Psi) - Normally open

level-controlled · drainage without pressure loss | incl. alarm

Type	Capacity*	Inflow	Voltage
	cfm		
KN100-HP50-115-NO	3530	1/2"	115 V · 50-60 Hz
KN100-HP50-24ac-NO	3530	1/2"	24 V ac
KN100-HP50-24dc-NO	3530	1/2"	24 V dc

* compressor connected load

KONDRAIN® KN100-HP50 (up to 725 Psi) - Normally closed

level-controlled · drainage without pressure loss | incl. alarm

Type	Capacity*	Inflow	Voltage
	cfm		
KN100-HP50-115-NC	3530	1/2"	115 V · 50-60 Hz
KN100-HP50-24ac-NC	3530	1/2"	24 V ac
KN100-HP50-24dc-NC	3530	1/2"	24 V dc

* compressor connected load

KONDRAIN® KMT

Time-controlled Condensate Drains with Free Adjustable Interval Times



Specification Model	KMT
Output: Compressor	2120 cfm
Output: Dryer	4240 cfm
Output: Filter	21190 cfm
Operating pressure	3 to 232 Psi
Operating temperature	34 to 149 °F
Available voltage classes	115 V 50/60 Hz
Protective class	IP 65

KONDRAIN® KMT-HP

Time-controlled Condensate Drain · High Pressure



KONDRAIN® KMT-HP80 (up to 1160 Psi · stainless steel valve) time-controlled with free adjustable inter-

Type	Capacity* cfm	Inflow	Voltage
KMT-HP80-115	unlimited	1/4"	115 V · 50-60 Hz
KMT-HP80-24ac	unlimited	1/4"	24 V ac
KMT-HP80-24dc	unlimited	1/4"	24 V dc

*Compressor capacity

KONDRAIN® KMT-HP250 (up to 3626 Psi · stainless steel valve) time-controlled with free adjustable intervals

Type	Capacity* cfm	Inflow	Voltage
KMT-HP250-115	unlimited	1/4"	115 V · 50-60 Hz
KMT-HP250-24ac	unlimited	1/4"	24 V ac
KMT-HP250-24dc	unlimited	1/4"	24 V dc

*Compressor capacity

KONDRAIN® KMT-HP350 (up to 5076 Psi · stainless steel valve) time-controlled with free adjustable intervals

Type	Capacity* cfm	Inflow	Voltage
KMT-HP350-115	unlimited	1/4"	115 V · 50-60 Hz
KMT-HP350-24ac	unlimited	1/4"	24 V ac
KMT-HP350-24dc	unlimited	1/4"	24 V dc

*Compressor capacity

KONDRAIN® KMT-HP500 (up to 7252 Psi · stainless steel valve) time-controlled with free adjustable intervals

Type	Capacity* cfm	Inflow	Voltage
KMT-HP500-115	unlimited	1/4"	115 V · 50-60 Hz
KMT-HP500-24ac	unlimited	1/4"	24 V ac
KMT-HP500-24dc	unlimited	1/4"	24 V dc

*Compressor capacity

Dimensional Drawings

KN100-HP50

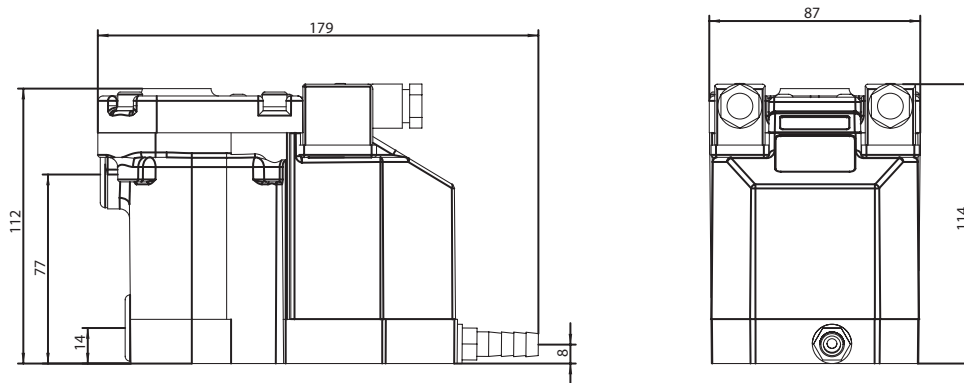

KMT-HP80 | KMT-HP250 | KMT-HP350 | KMT-HP500

