

Activated carbon adsorber CTAP130

Rev 01_1224

Technical data sheet

Page 1 of 2

| Nominal capacity (based on ambient conditions 14.5 psi, 68°F) | Unit | Design data |
|---|-------------------|-------------|
| Volume flow inlet | scfm | 130 |
| Volume flow outlet | scfm | 65 |
| Compressed air inlet temperature | °F | 95 |
| Working pressure | psig | 102 |
| Residual oil content | mg/m ³ | < 0,003 |

| General data | Unit | Design data |
|-----------------------------|------|------------------|
| Maximum operating pressure | psig | 195.75 |
| Minimum operating pressure | psig | 0 |
| Maximum inlet temperature | °F | 122°F (77° eff.) |
| Ambient temperature minimum | °F | 35.6 |

| Norms and key figures | Unit | Design data |
|-----------------------|------|-------------------|
| North America | | ASME B31.3 - 2020 |
| Canada | | CSA B-51 |
| Testing pressure | psig | 348 |

| Scope of supply | Unit | Design data |
|-----------------------------------|------|---------------------------|
| Ready-to-operate adsorption dryer | Type | CTAP130 |
| Final filter | Type | APF130-1DMF |
| Filling | Type | Activated carbon dedusted |
| Oil indicator A-4000-120 | | no |

| Options | Unit | Design data |
|------------|------|-------------|
| Pre filter | Type | APF130-1SMA |

Activated carbon adsorber CTAP130

Rev 01_1224

Technical data sheet

| Dimensions and weights | Unit | Design data |
|----------------------------------|--------|----------------|
| A | inch | 52.32 |
| B1 | inch | 49.17 |
| B2 | inch | 27.03 |
| C | inch | 15.01 |
| D | inch | 21.35 |
| Nominal size inside the adsorber | inch | 1" |
| Connection inlet | inch | 1" NPT |
| Connection outlet | inch | 1" NPT |
| Total weight | lbs | 154 |
| Volume (chamber) | gallon | 7,68 (2x 3,84) |

Dimensional drawings

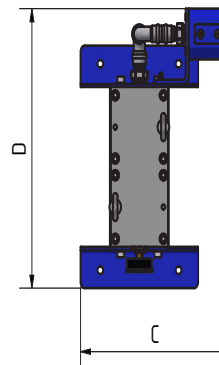
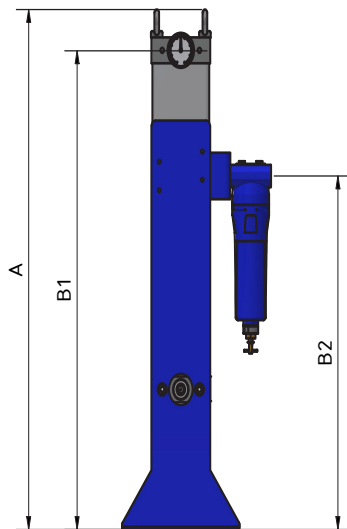

| Correction factors | |
|--------------------|---|
| Inlet temperature | |
| °F | < 77 77 86 95 100 104 113 118 122 |
| F(t) | 1.2 1.1 1.09 1 0.84 0.78 0.72 0.65 0.58 |

| Correction factors working pressure | | | | | | | | | | | | | | | | | | | | | | | | | |
|-------------------------------------|-----|-----|------|------|------|------|-----|------|------|------|------|------|------|------|-----|------|------|------|------|------|-----|------|------|-----|------|
| psig | 58 | 65 | 72.5 | 80 | 87 | 94 | 102 | 109 | 116 | 123 | 130 | 138 | 145 | 152 | 160 | 167 | 174 | 181 | 189 | 196 | 203 | 210 | 218 | 225 | 232 |
| F(p) | 0.6 | 0.7 | 0.74 | 0.82 | 0.89 | 0.97 | 1 | 1.08 | 1.11 | 1.16 | 1.22 | 1.29 | 1.36 | 1.42 | 1.5 | 1.57 | 1.63 | 1.69 | 1.75 | 1.83 | 1.9 | 1.96 | 2.03 | 2.1 | 2.14 |

Please multiply the capacity with the correction factors in the above table