

KSI ECOTROC® Operating manual Refrigeration dryers KTA-S14 - 1890

Rev. 02_0626



Table of contents

1	Introduction	3
2	Warranty	3
3	Characters and symbols used	4
4	Safety instructions	4
5	Field of application	5
6	Function	5
6.1	Heat exchanger	5
6.2	Solenoid drain valve	6
6.3	Digital controller.....	6
6.4	Refrigerant compressor	6
6.5	Condenser.....	6
6.6	Automatic expansion valve.....	6
6.7	Condensation control pressure switch.....	6
7	Technical data	6
8	Transportation	8
9	Storage	8
9.1	Storage for less than 12 months.....	8
9.2	Storage for more than 12 months.....	8
10	Installation	8
10.1	By-pass installation	9
10.2	Parallel installation	10
11	Commissioning	10
12	Stop instructions	11
13	Start instructions	11
14	Maintenance	11
15	Troubleshooting	12
15.1	A - High temperature of the compressed air at inlet	12
15.2	B – Excessive ambient temperature (for air condensation).....	12
15.3	C – Cooling system condensation failure	13
15.4	D – Low compressed air inlet pressure	13
15.5	E – Low ambient temperature (for air cooling)	13
15.6	F – Failures in the drainage system	13
15.7	G – Drowning of the dryer by the condensed water from the aftercooler	13
15.8	H – Loss of refrigerant gas	13
16	System layout recommendation	14
17	Digital controller	14
17.1	Introduction	14
17.2	Purpose.....	15
17.3	Features	15
17.4	Editable parameters	16

1 Introduction

This installation and operating manual is intended to help you familiarise yourself with the product and use it for its intended purpose. In addition, the instructions contain important information on safe, proper and economical operation. All instructions in this manual must be carried out in the specified manner to avoid hazards and damage. Furthermore, the respective regional regulations for accident prevention and the recognised technical rules for safe and professional work apply. Every person in the user's company who is responsible for the setup, commissioning, maintenance, repair and function monitoring of the product must have read and understood the instructions. They must always be available at the place of use. The manufacturer cannot be held liable for misinterpretations of the Operating manual and errors made by the operator.

2 Warranty

KSI ECOTROC® dryers are carefully checked at the factory and handed over to the transport company in perfect condition. Nevertheless, please check the goods for visible damage and insist on a corresponding note on the proof of receipt. The manufacturer is not responsible for any damage caused during transport (delivery ex works!).





The KSI ECOTROC® compressed air dryers are manufactured according to the state of the art and are subjected to extensive testing, including safety testing, before delivery.

Nevertheless, hazards to persons or property can arise if:

- the operating personnel are not trained,
- the product is not used as intended,
- the instructions in this manual are not implemented,
- the product is not maintained and serviced in accordance with the manufacturer's instructions,
- is improperly maintained or serviced.

This may result in the loss of any warranty claims.

3 Characters and symbols used

Symbol	Meaning
	Note This symbol indicates instructions for safe handling of the system and tips for efficient use of your system.
	Danger from compressed air This symbol indicates danger from compressed air.
	Warning of biohazard! This symbol indicates a possible biological hazard.
	General protective measures This symbol indicates that due to the hygiene regulations suitable gloves must be worn!

4 Safety instructions



The personnel for installation, commissioning, servicing and maintenance and for daily operation must have the appropriate qualifications for the respective task. They must



- be familiar with and instructed in the use of compressed air and know the corresponding hazards,
- know the contents of these instructions,
- have the appropriate training or authorisation.



Wear suitable gloves when replacing or opening the housing to avoid the possible transmission of infections or diseases.

Depressurise the housing before starting any work!

To ensure safe operation, the product must be operated within the application limits (operating pressure, operating temperatures, volume flows, material resistance etc.).

For safety and operational reasons, the compressed air supply must be switched off immediately in the event of a leak and the leakage eliminated.

The dryer and accessories must be checked regularly.

5 Field of application

i KSI ECOTROC® KTA-S dryers are designed to eliminate moisture from compressed air systems. This moisture might otherwise bring undesirable consequences, such as pipe oxidation, deterioration of sealings, paint imperfections, errors in reading instruments, frequent maintenance on pneumatic equipment, inaccuracies in pneumatic movements etc.

6 Function

i The main components are described below:

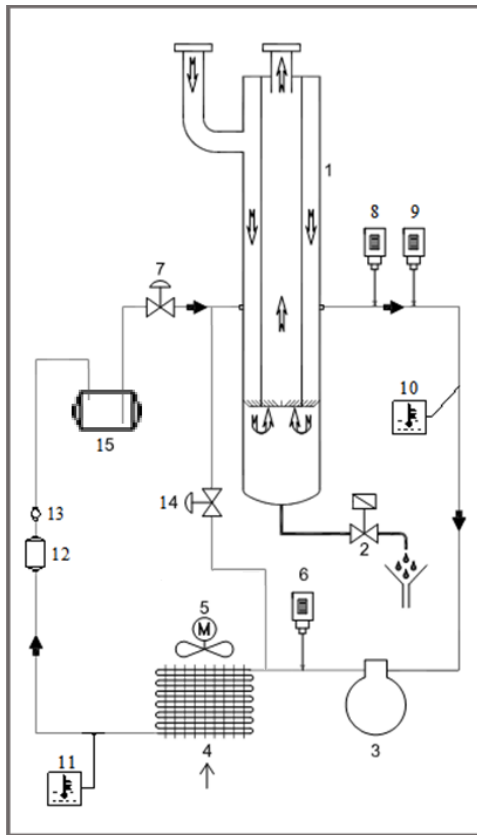

1	Evaporator/Heat exchanger	
2	Condensate drain	
3	Compressor	
4	Condenser	
5	Fan	
6	Control pressure switch	
7	Expansion valve	
8	High pressure switch	from KTA-S635
9	Low pressure switch	from KTA-S635
10	Cooling temperature sensor	
11	Ambient temperature sensor	
12	Filter dryer	from KTA-S176
13	Liquid visor	from KTA-S1420
14	Hot-gas bypass	from KTA-S1420
15	Liquid tank	from KTA-S1420

6.1 Heat exchanger

The heat exchanger is divided into three distinct parts:

AIR-TO-AIR HEAT EXCHANGER: responsible for pre-cooling of the compressed air that enters the dryer and the post-heating of the compressed air that leaves the dryer

EVAPORATOR: responsible for heat transfer between the pre-cooled wet compressed air and refrigerant, reducing the air temperature to 37.4°F/3°C

CONDENSATE SEPARATOR: separates and drains (automatically) the condensate from the system

6.2 Solenoid drain valve

Responsible for condensate removal from the system

6.3 Digital controller

Controls the opening of the solenoid valve, monitors the ambient temperature and cooling temperature in the evaporator

6.4 Refrigerant compressor

Responsible for the operation of the refrigerant system. The compressor is airtight for all models, except for special configurations

6.5 Condenser

Responsible for cooling/condensing the refrigerant. The standard for dryers of KTA-S line is air-cooled condensers

6.6 Automatic expansion valve

Controls the flow of the refrigerant in the evaporator

6.7 Condensation control pressure switch

Controls condensation pressure within a pre-set range to guarantee the refrigerant condenses at the right temperature

7 Technical data

Dryers with Serial no. BEFORE 24/163308

Model	Capacity	Connection	Weight	Power supply	Installed power
-	cfm	-	lbs	V / Ph / Hz	HP
KTA-S14	14	1/4" NPT	77	110 / 1 / 60	0.2
KTA-S35	35	3/4" NPT	86	110 / 1 / 60	0.5
KTA-S47	47	3/4" NPT	86	110 / 1 / 60	0.5
KTA-S85	85	1" NPT	90	110 / 1 / 60	0.8
KTA-S118	118	1 1/2" NPT	128	110 / 1 / 60	1.9
KTA-S176	176	1 1/2" NPT	187	220 / 1 / 60	2.0
KTA-S235	235	1 1/2" NPT	209	220 / 1 / 60	2.4
KTA-S306	306	2" NPT	227	220 / 1 / 60	3.2
KTA-S376	376	2" NPT	407	220 / 1 / 60	3.2
KTA-S470	470	2" NPT	407	220 / 1 / 60	4.4
KTA-S635	635	3" flange	495	220 / 3 / 60	5.0

KTA-S753	753	3" flange	550	220 / 3 / 60	5.5
KTA-S945	945	3" flange	605	220 / 3 / 60	6.8
KTA-S1180	1180	4" flange	638	220 / 3 / 60	10.2
KTA-S1420	1420	4" flange	772	220 / 3 / 60	9.2
KTA-S1890	1890	4" flange	904	220 / 3 / 60	11.6

Dryers with Serial no. AFTER 24/163309

Model	Capacity	Connection	Weight	Power supply	Installed power
-	cfm	-	lbs	V / Ph / Hz	HP
KTA-S14	14	1/4" NPT	77	115 / 1 / 60	0.2
KTA-S35	35	3/4" NPT	86	115 / 1 / 60	0.3
KTA-S47	47	3/4" NPT	86	115 / 1 / 60	0.7
KTA-S85	85	1" NPT	90	115 / 1 / 60	1.1
KTA-S118	118	1 1/2" NPT	128	115 / 1 / 60	1.4
KTA-S176	176	1 1/2" NPT	187	230 / 1 / 60	1.6
KTA-S235	235	1 1/2" NPT	209	230 / 1 / 60	1.6
KTA-S306	306	2" NPT	227	230 / 1 / 60	2.1
KTA-S376	376	2" NPT	407	230 / 1 / 60	2.8
KTA-S470	470	2" NPT	407	230 / 1 / 60	3.3
KTA-S635	635	3" flange	495	460 / 3 / 60	3.8
KTA-S753	753	3" flange	550	460 / 3 / 60	4.9
KTA-S945	945	3" flange	605	460 / 3 / 60	6.6
KTA-S1180	1180	4" flange	638	460 / 3 / 60	8.3
KTA-S1420	1420	4" flange	772	460 / 3 / 60	11.0
KTA-S1890	1890	4" flange	904	460 / 3 / 60	13.3

8 Transportation

Always transport the equipment in upright position, respecting the instructions on the packaging. It is strictly prohibited to transport the dryer in horizontal position or with an inclination greater than 15°.

The dryer may not be dropped under any circumstances. This may compromise the operation of its components in addition to loss of warranty.

9 Storage

9.1 Storage for less than 12 months

- Keep the dryer in a sheltered and dry place, in upright position
- If possible, keep the original packaging of the dryer
- Keep the dryer, when unpacked, away from aggressive environment that may compromise its conservation
- Ensure that the dryer connections are properly protected in order to avoid internal corrosion
- Ensure that the dryer is in a safe place to avoid damage from hitting or scratching from other objects, or possibility of falling

9.2 Storage for more than 12 months

- Proceed as per item 9.1
- Unpack the dryer, check the condition of the dryer and report to the supplier if any damage or malfunction is noticed
- Connect the dryer to appropriate electrical power (check if the mains voltage and power are compatible with the equipment)
- For regular air-cooled KTA-S dryer check the fan has not been damaged during transportation or storage
- Allow the dryer to run for more than 15 minutes and observe the correct operation of the items listed below. If any of the following is observed, contact your supplier:
Compressor: Place your hand on the housing to check for vibration that may indicate its operation. Check that the housing is cool and the noise produced is not excessive
Motor exhaust fans: Check that all fans are working and that the air is blown towards the removable door at the front of the unit
Solenoid drain valve: Check operation
- After performing these tests, dry all components that have external condensation, repack the dryer and return to its storage place.
This procedure should be performed every 6 months, starting from 12 months of storage

10 Installation

Remove the dryer from its packaging and ensure that there has been no damage due to transportation.

The equipment should be installed in a sheltered location. It is recommended to maintain a minimum distance between the wall and the dryer of approximately 2 feet/0.5 m on each side due to air cooling.

There is no need to install the equipment into concrete/floor. The dryer should rest on a level base.

The perfect functioning of the compressed air dryer depends on the quality of the air to be treated by it. It is mandatory to install a filter at the inlet of the dryer so that there is no loss in the performance of the heat exchanger and no obstruction of the draining system. Not applying compressed air at the dryer inlet with minimum quality required, as indicated below, will make the equipment lose its warranty:

Removal of particles down to 1 micron;

Maximum residual oil of F @ 69.8°F (21°C);

There is no excess condensate that could compromise the dryer's drainage system;

NOTE: Minimum ISO 8573-1 class required at dryer inlet (2/-/3)

Connect the dryer to the compressed air line after the air receiver and make sure the flow direction is correct (inlet/outlet).

The operating pressure and temperature of the dryer must be suitable for the selected model – check catalog.

Check that the maximum compressed air pressure of the dryer meets the maximum mains pressure.

The dryer should not receive vibration from the compressed air piping.

The hose at the bottom of the dryer should be attached to a suitable condensate management system.

10.1 By-pass installation

The installation of a by-pass of the dryer facilitates its maintenance without cutting the supply of compressed air on the installation lines. However, if the by-pass is used, the entire installation will be contaminated with moisture.

To minimize the problems from the use of by-passes, it is recommended that the pipe does not contain vertical U curves, where water could accumulate. Installing coalescing filters downstream of the dryer will also minimize the problem, but the correct solution is to install a backup dryer.

10.2 Parallel installation

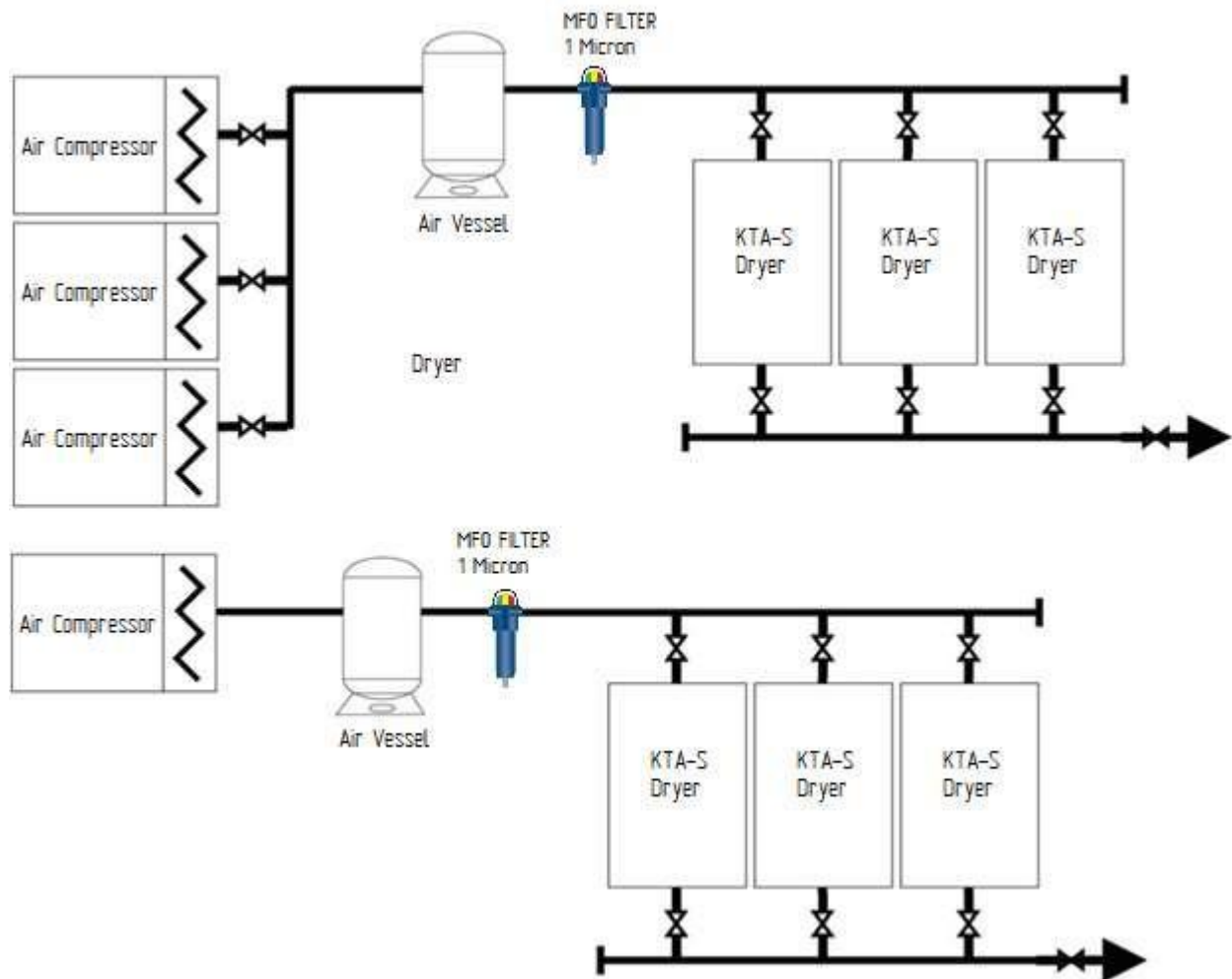

Note:

Only equipment of equal capacities and pressure losses must be installed. It is not recommended to install different models of dryers in parallel.

11 Commissioning

Make sure the previous instructions have been followed.

Make sure that the supply voltage is the same as indicated on the dryer rating plate.

BEFORE DRYER COMMISSIONING, IT IS NECESSARY TO CHECK ALL ELECTRICAL CONNECTIONS. DUE TO TRANSPORTATION, THE CONNECTIONS MAY GET LOOSE AND THAT MAY LEAD TO AN ELECTRICAL COMPONENT TO GETTING DAMAGED/BURNED.

Note:

Pressurize the dryer while keeping the mains compressed air outlet valve closed.

Start by actuating the power key on the front panel of the dryer.

Wait approximately 10 minutes for the refrigeration system to come into equilibrium and slowly open the outlet valve of the compressed air mains.

Check the regular operation of the dryer, i.e.:
Condensate drain through the hose at the bottom of the dryer;
Cooling of the heat exchanger, which can be perceived by contact with the region just above the insulation;
Dry air (look for an air consumption point near the dryer, and visually check that there is no water in the line);
Free passage of compressed air through the dryer.

IMPORTANT:

A - Draining frequency is pre-configured from the factory. If the standard frequency does not suffice to drain all condensate formed, it is possible to adjust it on the digital controller.

B – Do not make any other adjustment in the refrigeration circuit of the dryer. All necessary adjustment have been done in the factory before shipping. To prevent and identify any changes, the components are sealed in the factory.

12 Stop instructions

Close the compressed air valve at the dryer outlet.
Turn off the compressor or close the compressed air valve at the dryer inlet.
Turn off the dryer:

13 Start instructions

Switch on the dryer (see item 11).
Turn on the compressor or open the compressed air valve at the dryer inlet.
Wait approximately 10 minutes for the refrigeration system to come into equilibrium and slowly open the outlet valve of the compressed air mains.

14 Maintenance

The cooling system does not require periodic maintenance. The following checks are recommended:

Dirt on the air condenser – the condenser should be inspected periodically and cleaned if necessary. Partial blockage of the condenser may cause an increase in the temperature and pressure of the refrigeration system, causing compressor breakdown and loss of warranty.

The drainage system should be inspected periodically.

WARNING: Never carry out maintenance on the refrigeration circuit and/or a heat exchanger, with the dryer pressurized and/or energized, in order to avoid accidents.

15 Troubleshooting

The dryers are fully inspected and put into operation in our factory, however if any faults occur, please check the following list of faults and **probable causes**:

PROBLEM	PROBABLE CAUSES	ITEM
Dryer is turned on and not breaks or breaks and turns off	Cut by compressor thermal protector	a/b/c/g/h
Dryer operates, but water appears in the air line	Blocked or broken drain system	f
	Dryer flooded by condensate	g
	Refrigerant (refrigerant gas) charge loss	h
Dryer causes high pressure drop in compressed air network	Evaporator (refrigerant gas) blocked by frost	e
	Dryer operating with excessive compressed air flow or too low pressure	d

15.1 A - High temperature of the compressed air at inlet

Too high a temperature of the compressed air at the inlet can place an excessive thermal load on the refrigerator compressor. The initial symptom is an increase in the temperature of the refrigerator (refrigerant gas) in the suction to values above 32 °F (0°C), followed by the cutting of the

compressor by thermal protector. Once the compressor body temperature drops, the protector is rearmed allowing the compressor to depart. However, while the dryer is stationary, it is possible that water may appear in the compressed air line.

It is recommended that the cause of the over-inlet temperature of the compressed air be determined and eliminated, as it will impair the performance of the air dryer.

15.2 B – Excessive ambient temperature (for air condensation)

High temperature at the dryer installation site will reduce the possibility of condensing airflow removing the heat generated by the dryer. This undissipated heat will cause an increase in the suction and discharge pressures of the refrigerator (refrigerant gas), causing the dryer to shut down, in the same way as in the case of excess inlet

temperature. Also in this case, water may appear in the compressed air line. If the ambient temperature is always too high, it is recommended that the dryer be installed elsewhere or that the condenser be water or that the dryer be sized appropriately to work under special conditions.

15.3 C – Cooling system condensation failure

AIR CONDENSATION: Fan failures, dirty or blocked condenser, or insufficient circulating air are problems that will have the same consequences as excessive room temperature (see 10.2).

WARNING: For dryers that have condensation control, the fan will turn off in the event of a low thermal load, which should not be confused with fan failure.

15.4 D – Low compressed air inlet pressure

When the dryer operates at full compressed air flow rate and at abnormally low pressure, a combination of symptoms may be observed. Increasing the speed of the air through the dryer will certainly cause an excessive loss of pressure. The high speed can also carry moisture through the separator, which will appear in the compressed air line. The larger amount of water contained in a low- pressure airflow will also cause the same symptoms as the over-temperature of compressed air (see item a).

15.5 E – Low ambient temperature (for air cooling)

If the temperature at the dryer installation location is too low, this can result in a very high rate of cooling in the condenser. When this occurs along with a low inlet temperature and a low compressed air flow, it can result in the formation of ice

in the air-to-coolant (refrigerant gas) exchanger. This can cause excessive pressure loss in the dryer and even blockage.

15.6 F – Failures in the drainage system

The symptom of failure in the drainage system is the absence of water at the drain outlet and its appearance in the compressed air pipe.

15.7 G – Drowning of the dryer by the condensed water from the aftercooler

If the condensate separation system of the compressed air compressor's *after-cooler* fails, the condensate water goes into the dryer. As a result, there is an increase in thermal load, triggering the same symptoms of high temperature at the entrance (See 15.1). At the same time, excess water can overwhelm the dryer's operating capacity.

15.8 H – Loss of refrigerant gas

The dryer is delivered with the necessary load for its satisfactory operation. But refrigerant (refrigerant gas) leakage may occur at the pipe joints during service. The initial symptom of the loss of refrigerator (refrigerant gas) is the lack of cooling in the separator region. Water may also appear in the compressed air network. The refrigerated compressor can continue to operate at partial load, but the system will only be circulating refrigeration (refrigerant gas) and the consequent increase in heat will

cause it to stop by the compressor's thermal protector or low pressure switch; In both cases, the reset is automatic.

It is important that the dryer does not operate in these conditions, as this may cause permanent damage or burning of the compressor motor.

16 System layout recommendation

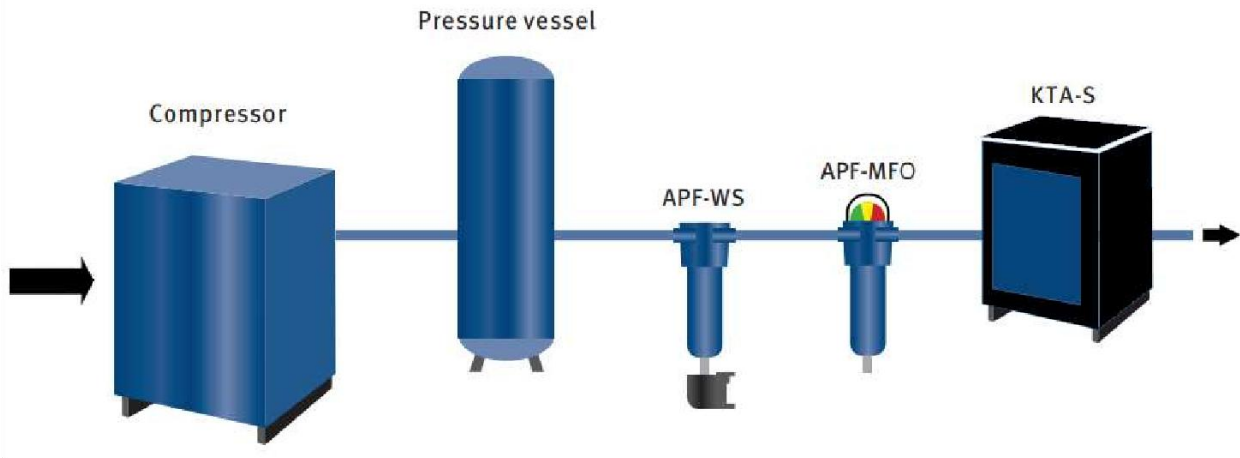

Note:

Coalescing filters are not part of the dryer and are therefore not included in the scope of delivery of the equipment.

17 Digital controller



Digital controller for KTA-S dryers – illustrative image

17.1 Introduction

The digital controller used in KTA-S dryers is manufactured by COELMATIC, by ASCON TECNOLOGIC S.r.l. model E33 – the information contained in this section is based on the manual "[E31-E33-SERIES-INS-EN.pdf](#)" and has been adapted for the application of KTA-S dryers. The source document is available under:

<https://www.tme.eu/Document/999bfca21a23df1a79641612107412f4/E31-E33-SERIES-INS-EN.pdf> ".

17.2 Purpose

The purpose of the Electronic Controller is to indicate to the user the cooling temperature of the system and the ambient temperature, through sensors installed in appropriate positions. Another important function is to control the actuation time and frequency of the dryer's purge solenoid valve and to prevent condensate freezing by putting the compressor on standby mode if the compressed air load is too low.

17.3 Features



1. P key: used to access programming parameters (hold for 5 seconds). In programming mode it is used to enter the mode of editing the parameters and to confirm the values. In programming mode, it can be used together with the UP button to change the access level of the parameters. When the keyboard is locked, the P key can be used together with the UP key (hold both for 5 seconds) to unlock the keyboard.
Editable parameters are explained in section XX.
2. DOWN key: in programming mode it is used to decrease the values to be set and to select the parameters.
3. UP/PURGE key: In normal mode it can be used to start/stop condensate drain manually (hold for 5 seconds). In programming mode it is used to increase the values to be set and to select the parameters. In programming mode, it can be used together with the P key to change the access level of the parameters. Pressing the P key and UP/purge key for 5 seconds allows you to unlock the keyboard.
4. U key: Power on/off (stand-by) by pressing the U key for 2 seconds. Used to view dryer variables (ambient and cooling temperature) by pressing the U key and releasing directly. In programming mode it can be used to return to normal mode (press for 5 seconds).
5. LED alarm: indicates temperature alarm (LED on), off (LED off), muted or stored (LED flashing).
 - a. High cooling temperature alarm on: temperature > 50°F/10°C
 - b. Low cooling temperature alarm on: temperature < 30.2°F/-1°C
6. Compressor LED: indicates compressor status as being on (LED on) or off (LED off). It should always be ON.
7. Purge LED: indicates drain in progress with solenoid valve open (LED on) or solenoid valves closed (LED off).

17.4 Editable parameters

Parameter	Description	Values	Pattern	Note.:
lds	Variable normally displayed on the display: P1 = cooling temperature / P2 = ambient temperature	P1 / P2 / P3 / Ec / SP / oF	P1	
dde	Condensate Drain Solenoid Valve Opening Time	oF/ -1 to -59 (s) / 1 to 99 (min)	-5	
DDI	Condensate Drain Solenoid Valve Opening Frequency	oF/ -1 to -59 (min) / 1 to 99 (hrs)	-3	
AHA	High Temperature Alarm Value	oF / -99.9 to 999 °C/°F	50°F 10°C	
WING	Low Temperature Alarm Value	oF / -99.9 to 999 °C/°F	30.2°F -1°C	

OBU	<p>How the buzzer works</p> <p>oF = disabled</p> <p>1 = for active alarms only</p> <p>2 = signals keypad touch</p> <p>3 = enabled to signal alarms assets, then tap the keyboard</p>	oF / 1 / 2 / 3	3	
tLo	Time for automatic keypad lock	oF/ -1 to -59 (s) / 1 to 99 (min)	oF	
tPP	Password to access the configuration of the parameters	oF to 999	33	If required, the password can be redifined by the user.***
lup	<p>Unit of measurement and resolution (decimal point)</p> <p>C0 = °C with 1° variation</p> <p>F0 = °F with 1° variation</p> <p>C1 = °C with 0,1° variation</p> <p>F1 = °F with 0,1° variation</p>	C0 / F0 / C1 / F1	C1	

***IMPORTANT: If the password is changed by the user, it cannot be reset to factory default. The controller must be sent to KSI for reconfiguration if the password is lost.